

HONEMATIC

CAPABILITIES

ID HONING

40" O.D. Max Swing
24" I.D. Max
25' Lengths

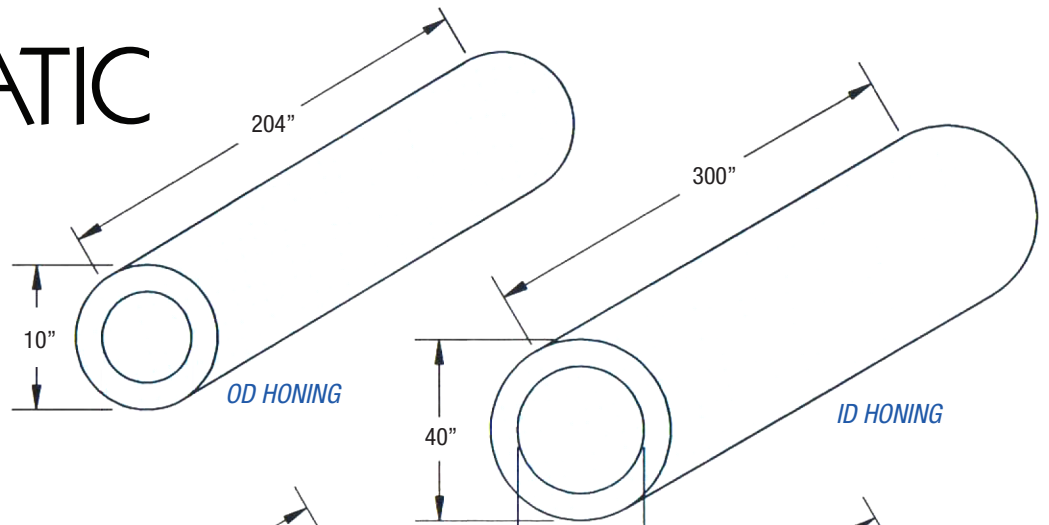

OD HONING

10" O.D. Max
17' Lengths

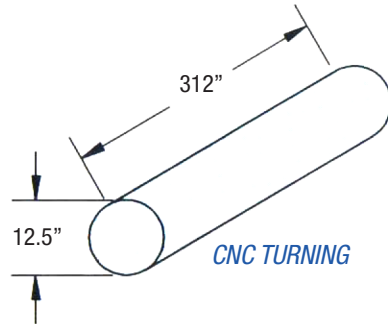

CNC TURNING

59" O.D.
20' Centers
12.5" O.D.
26' Centers

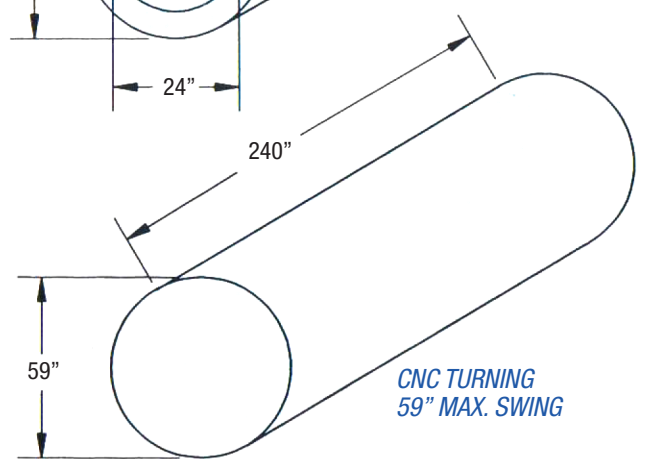

CNC VERTICAL MILLING

141" X Travel
36" Y Travel
32" Z Travel

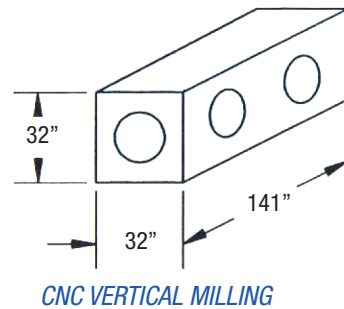

CNC HORIZONTAL MILLING

98" X Travel
79.75" Y Travel
27.50" Z Travel

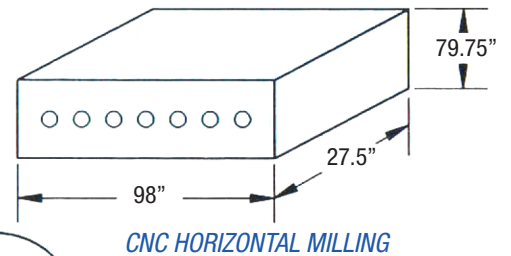

CNC BORING

55" Max I.D.
120" Max Depth

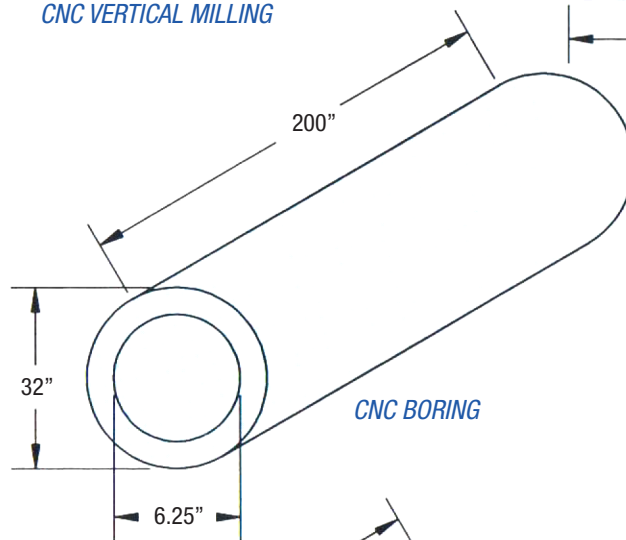

GUNDRILLING

.25" to 1.5" I.D.
340" Max Depth

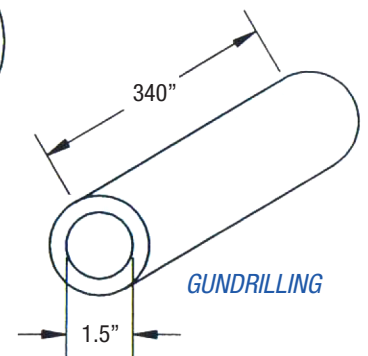

TREPANNING

6.25" Max I.D.
200" Max Depth

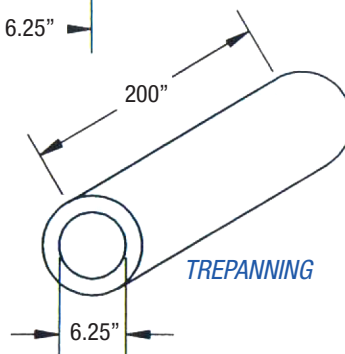

BTA DRILLING

5.125" Max I.D.
340" Max Depth

